

COS/MOS INTEGRATED CIRCUITS

HBC/HBF 4000A
HBC/HBF 4001A
HBC/HBF 4002A
HBC/HBF 4025A

NOR GATES: DUAL 3 INPUT PLUS INVERTER HBC/HBF 4000A
QUAD 2 INPUT HBC/HBF 4001A
DUAL 4 INPUT HBC/HBF 4002A
TRIPLE 3 INPUT HBC/HBF 4025A

- QUIESCENT CURRENT SPECIFIED TO 15V (see page 10)
- MAX. INPUT LEAKAGE CURRENT $1 \mu\text{A}$ @ 15V (FULL TEMP. RANGE)
- HIGH NOISE IMMUNITY: 45% of V_{DD} (TYP.)
- MEDIUM SPEED OPERATION: $t_{PHL} = t_{PLH} = 25 \text{ ns}$ (TYP.) at $C_L = 15 \text{ pF}$
- INPUTS FULLY PROTECTED
- LOW "1" and "0" OUTPUT LEVEL IMPEDANCE: 500Ω and 200Ω (TYP.), RESPECTIVELY at $V_{DD} - V_{SS} = 10\text{V}$
- HIGH FANOUT: > 50

The HBC 4000A, HBC 4001A, HBC 4002A, HBC 4025A (extended temperature range) and HBF 4000A, HBF 4001A, HBF 4002A, HBF 4025A (standard temperature range) NOR gates are constructed with MOS P-channel and N-channel enhancement mode devices in a single monolithic chip. These complementary MOS logic gates find primary use where low power dissipation and/or high noise immunity is desired.

They are available in 14-lead dual in-line plastic or ceramic package and ceramic flat package.

ABSOLUTE MAXIMUM RATINGS

$V_{DD}-V_{SS}$	Supply voltage	-0.5 to 15	V
V_i	Input voltage (at any pin)	$V_{SS} \leq V_i \leq V_{DD}$	
P_{tot}	Total power dissipation (per package)	200	mW
T_{stg}	Storage temperature	-65 to 150	°C
T_{op}	Operating temperature: for HBC types	-55 to 125	°C
	for HBF types	-40 to 85	°C

ORDERING NUMBERS:

HBC 4 XXX AD for dual in-line ceramic package
HBC 4 XXX AF for dual in-line ceramic package frit seal (extended temperature range)
HBC 4 XXX AK for ceramic flat package
HBF 4 XXX AE for dual in-line plastic package
HBF 4 XXX AF for dual in-line ceramic package frit seal (standard temperature range)

MECHANICAL DATA (dimensions in mm)

Dual in-line ceramic package
for HBC/HBF 4XXX AF

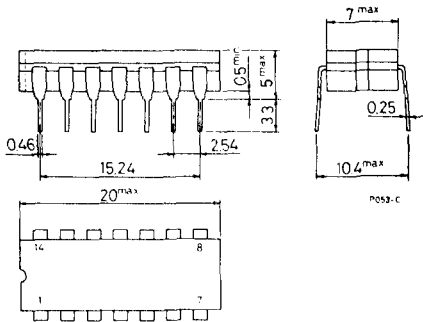

Dual in-line plastic package
for HBF 4XXX AE

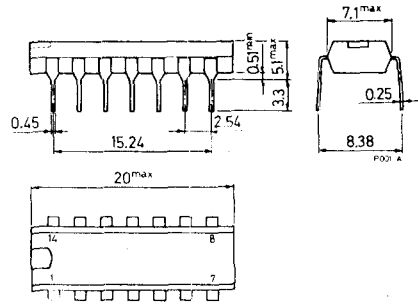

Dual in-line ceramic package
for HBC 4XXX AD

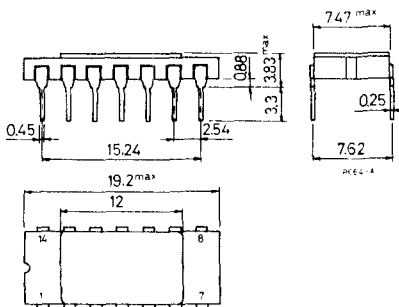

Ceramic flat package
for HBC 4XXX AK

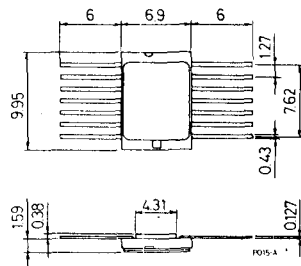

CONNECTION DIAGRAMS (top view)

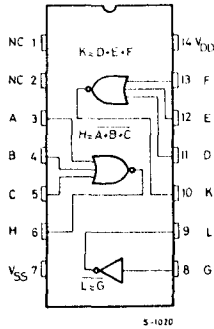

For 4000A

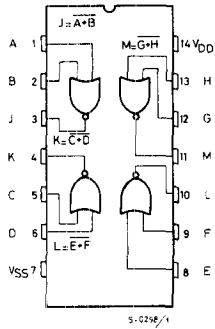

For 4001A

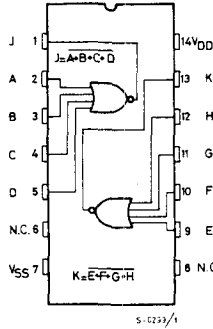

For 4002A

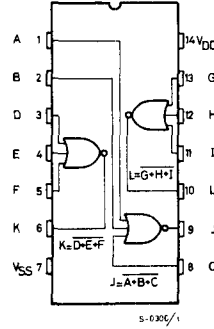

For 4025A

SCHEMATIC DIAGRAMS

For 4000A

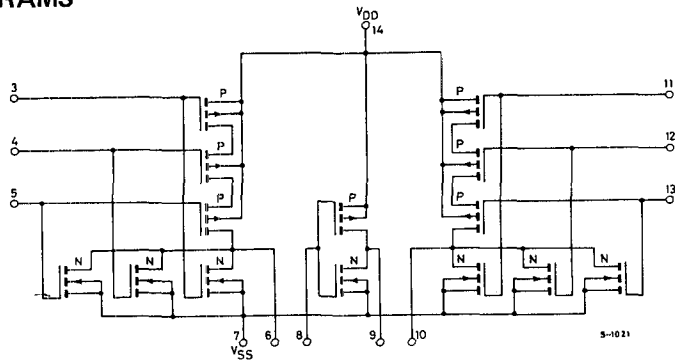

For 4001A

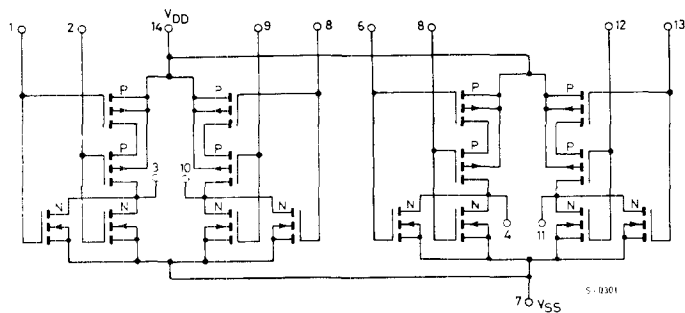

HBC/HBF 400A
HBC/HBF 4001 A
HBC/HBF 4002 A
HBC/HBF 4025A

SCHEMATIC DIAGRAMS (continued)

For 4002A

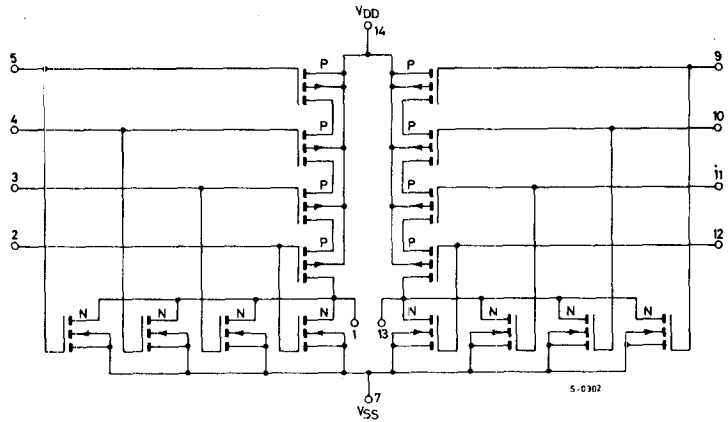

For 4025A

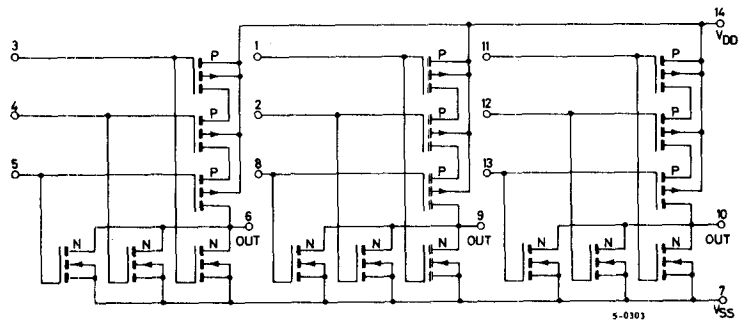

RECOMMENDED OPERATING CONDITIONS

V_{DD}^*	Supply voltage	3 to 15	V
V_i^*	Input voltage	V_{DD} to V_{SS}	
T_{op}	Operating temperature for HBC types	-55 to 125	°C
	for HBF types	-40 to 85	°C

* This is measured with respect to the V_{SS} pin voltage

STATIC ELECTRICAL CHARACTERISTICS

Parameter	Test conditions	Min. Typ. Max.	Unit
HBC types (extended temperature range)			
I_L Quiescent current (for values at 15V see page 10)	$V_{DD} = 5V$ at $T_{amb} = -55^\circ C$ at $T_{amb} = 25^\circ C$ at $T_{amb} = 125^\circ C$ $V_{DD} = 10V$ at $T_{amb} = -55^\circ C$ at $T_{amb} = 25^\circ C$ at $T_{amb} = 125^\circ C$	0.05 0.001 0.05 3 0.1 0.001 0.1 6	μA μA μA μA μA μA
V_{OH} Output high voltage	$I_o = 0$ $V_{DD} = 5V$ at $T_{amb} = -55^\circ C$ at $T_{amb} = 25^\circ C$ at $T_{amb} = 125^\circ C$ $V_{DD} = 10V$ at $T_{amb} = -55^\circ C$ at $T_{amb} = 25^\circ C$ at $T_{amb} = 125^\circ C$	4.99 4.99 5 4.95 9.99 9.99 10 9.95	V V V V V V
V_{OL} Output low voltage	$I_o = 0$ $V_{DD} = 5V$ or $10V$ at $T_{amb} = -55^\circ C$ at $T_{amb} = 25^\circ C$ at $T_{amb} = 125^\circ C$	0.01 0 0.01 0.05	V V V
V_{NH} Noise immunity	$V_{DD} = 5V$ $V_o = 0.95V$ at $T_{amb} = -55^\circ C$ at $T_{amb} = 25^\circ C$ at $T_{amb} = 125^\circ C$ $V_{DD} = 10V$ $V_o = 2.9V$ at $T_{amb} = -55^\circ C$ at $T_{amb} = 25^\circ C$ at $T_{amb} = 125^\circ C$	1.4 1.5 2.25 1.5 2.9 3 4.5 3	V V V V V V
V_{NL} Noise immunity	$V_{DD} = 5V$ $V_o = 3.6V$ at $T_{amb} = -55^\circ C$ at $T_{amb} = 25^\circ C$ at $T_{amb} = 125^\circ C$	1.5 1.5 2.25 1.4	V V V

STATIC ELECTRICAL CHARACTERISTICS (continued)

Parameter	Test conditions	Min.	Typ.	Max.	Unit
V_{NL} Noise immunity	$V_{DD} = 10V$ $V_o = 7.2V$ at $T_{amb} = -55^\circ C$ at $T_{amb} = 25^\circ C$ at $T_{amb} = 125^\circ C$	3 3 2.9	4.5		V V V
I_{DN} Output drive current N-channel	$V_{DD} = 5V$ $V_o = 0.4V$ at $T_{amb} = -55^\circ C$ at $T_{amb} = 25^\circ C$ at $T_{amb} = 125^\circ C$ $V_{DD} = 10V$ $V_o = 0.5V$ at $T_{amb} = -55^\circ C$ at $T_{amb} = 25^\circ C$ at $T_{amb} = 125^\circ C$	0.5 0.4 0.28 1.1 0.9 0.65	1		mA mA mA mA mA mA
I_{DP} Output drive current P-channel	$V_{DD} = 5V$ $V_o = 2.5V$ at $T_{amb} = -55^\circ C$ at $T_{amb} = 25^\circ C$ at $T_{amb} = 125^\circ C$ $V_{DD} = 10V$ $V_o = 9.5V$ at $T_{amb} = -55^\circ C$ at $T_{amb} = 25^\circ C$ at $T_{amb} = 125^\circ C$	-0.62 -0.5 -0.35 -0.62 -0.5 -0.35	-2		mA mA mA mA mA mA
I_{IH}, I_{IL} Input leakage current	$V_{DD} = 15V$ (any input)		$\pm 10^{-5}$	± 1	μA

HBF types (standard temperature range)

I_L Quiescent current (for values at 15V see page 10)	$V_{DD} = 5V$ at $T_{amb} = -40^\circ C$ at $T_{amb} = 25^\circ C$ at $T_{amb} = 85^\circ C$ $V_{DD} = 10V$ at $T_{amb} = -40^\circ C$ at $T_{amb} = 25^\circ C$ at $T_{amb} = 85^\circ C$		0.005	0.5 0.5 15 5 5 30	μA μA μA μA μA μA
V_{OH} Output high voltage	$I_o = 0$ $V_{DD} = 5V$ at $T_{amb} = -40^\circ C$ at $T_{amb} = 25^\circ C$ at $T_{amb} = 85^\circ C$	4.99 4.99 4.95	5		V V V

STATIC ELECTRICAL CHARACTERISTICS (continued)

Parameter	Test conditions	Min.	Typ.	Max.	Unit
V_{OH} Output high voltage	$I_o = 0$ $V_{DD} = 10V$ at $T_{amb} = -40^\circ C$ at $T_{amb} = 25^\circ C$ at $T_{amb} = 85^\circ C$	9.99			V
		9.99	10		V
		9.95			V
V_{OL} Output low voltage	$I_o = 0$ $V_{DD} = 5V$ or $10V$ at $T_{amb} = -40^\circ C$ at $T_{amb} = 25^\circ C$ at $T_{amb} = 85^\circ C$			0.01	V
			0	0.01	V
				0.05	V
V_{NH} Noise immunity	$V_{DD} = 5V$ $V_o = 0.95V$ at $T_{amb} = -40^\circ C$ at $T_{amb} = 25^\circ C$ at $T_{amb} = 85^\circ C$	1.4			V
		1.5	2.25		V
		1.5			V
	$V_{DD} = 10V$ $V_o = 2.9V$ at $T_{amb} = -40^\circ C$ at $T_{amb} = 25^\circ C$ at $T_{amb} = 85^\circ C$	2.9			V
		3	4.5		V
		3			V
V_{NL} Noise immunity	$V_{DD} = 5V$ $V_o = 3.6V$ at $T_{amb} = -40^\circ C$ at $T_{amb} = 25^\circ C$ at $T_{amb} = 85^\circ C$	1.5			V
		1.5	2.25		V
		1.4			V
	$V_{DD} = 10V$ $V_o = 7.2V$ at $T_{amb} = -40^\circ C$ at $T_{amb} = 25^\circ C$ at $T_{amb} = 85^\circ C$	3			V
		3	4.5		V
		2.9			V
I_{DN} Output drive current N-channel	$V_{DD} = 5V$ $V_o = 0.4V$ at $T_{amb} = -40^\circ C$ at $T_{amb} = 25^\circ C$ at $T_{amb} = 85^\circ C$	0.35			mA
		0.3	1		mA
		0.24			mA
	$V_{DD} = 10V$ $V_o = 0.5V$ at $T_{amb} = -40^\circ C$ at $T_{amb} = 25^\circ C$ at $T_{amb} = 85^\circ C$	0.72			mA
		0.6	2.5		mA
		0.48			mA

STATIC ELECTRICAL CHARACTERISTICS (continued)

Parameter	Test conditions	Min.	Typ.	Max.	Unit
I_{OP} Output drive current P-channel	$V_{DD} = 5V$ $V_o = 2.5V$ at $T_{amb} = -40^\circ C$	-0.35			mA
		-0.3	-2		mA
		-0.24			mA
	$V_{DD} = 10V$ $V_o = 9.5V$ at $T_{amb} = -40^\circ C$	-0.3			mA
		-0.25	-1		mA
		-0.2			mA
I_{IH}, I_{IL} Input leakage current	$V_{DD} = 15V$ (any input)	$\pm 10^{-5}$	± 1		μA

Minimum and maximum voltage transfer characteristic curves and test circuit

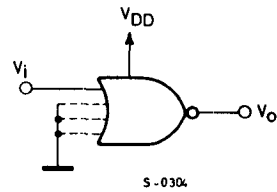
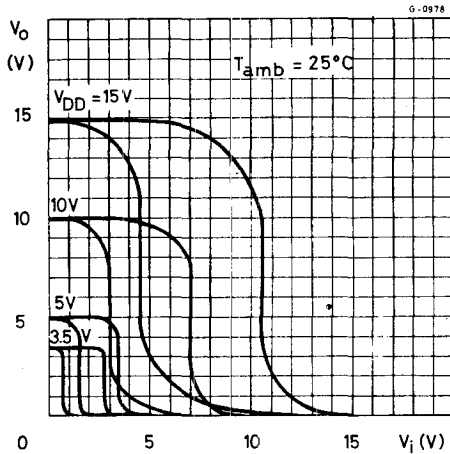

Typical current and voltage transfer characteristic curves and test circuit

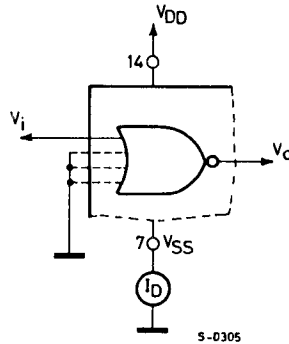
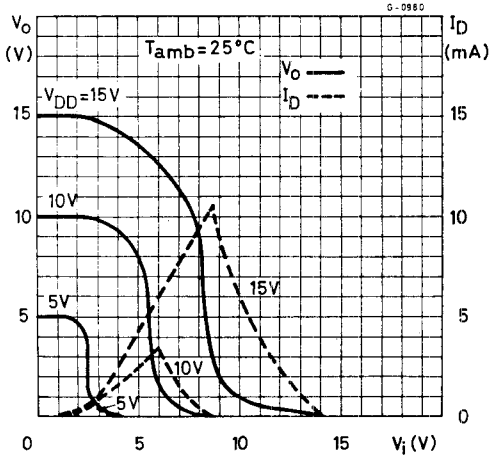

Typical voltage transfer characteristics vs. ambient temperature

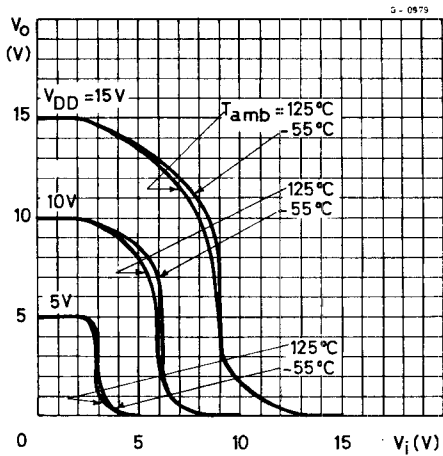

Typical power dissipation characteristics

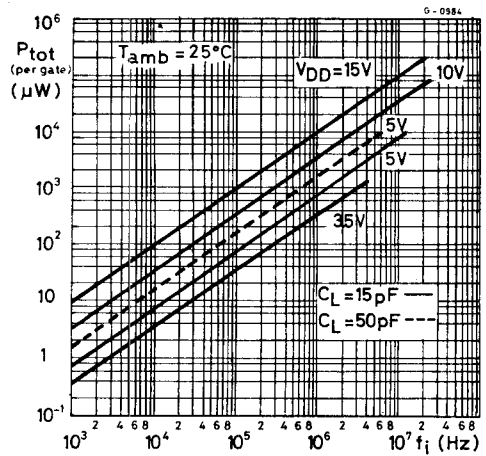

HBC/HBF 4000 A
HBC/HBF 4001 A
HBC/HBF 4002 A
HBC/HBF 4025 A

DYNAMIC ELECTRICAL CHARACTERISTICS ($T_{amb} = 25^{\circ}\text{C}$, $C_L = 15 \text{ pF}$, typical temperature coefficient for all $V_{DD} = 0.3\%/^{\circ}\text{C}$ values)

Parameter		Test conditions	Min.	Typ.	Max.	Unit
t_{PLH}	Propagation delay time (low to high level)	$V_{DD} = 5\text{V}$				
			for HBC types	35	95	ns
		for HBF types	35	120	ns	
		$V_{DD} = 10\text{V}$	for HBC types	25	45	ns
for HBF types	25		65	ns		
t_{PHL}	Propagation delay time (high to low level)	$V_{DD} = 5\text{V}$				
			for HBC types	35	50	ns
		for HBF types	35	80	ns	
		$V_{DD} = 10\text{V}$	for HBC types	25	40	ns
for HBF types	25		55	ns		
t_{TLH}	Transition time (low to high level)	$V_{DD} = 5\text{V}$				
			for HBC types	65	175	ns
		for HBF types	65	300	ns	
		$V_{DD} = 10\text{V}$	for HBC types	35	75	ns
for HBF types	35		125	ns		
t_{THL}	Transition time (high to low level)	$V_{DD} = 5\text{V}$				
			for HBC types	65	125	ns
		for HBF types	65	200	ns	
		$V_{DD} = 10\text{V}$	for HBC types	35	70	ns
for HBF types	35		115	ns		
C_i	Input capacitance	Any input for HBC and HBF types		5		pF

Typical propagation delay time vs. V_{DD}

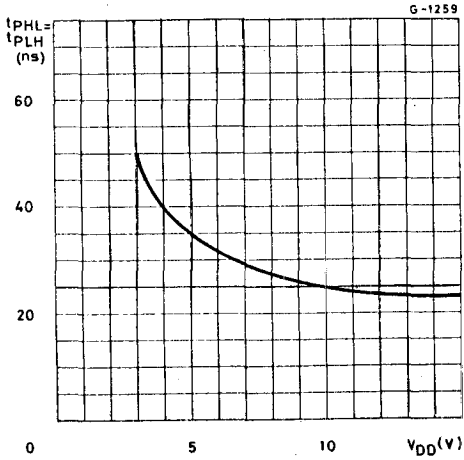

Typical propagation delay time vs. C_L

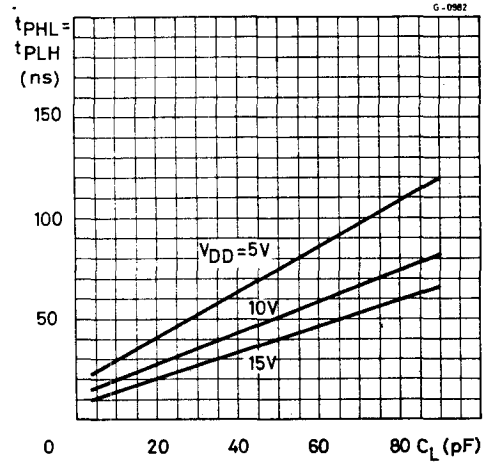

Typical transition time vs. C_L

